

## RACING HYDROGENERATOR

### Installation and instruction manual

Version	V4.1
Date	May 2019
Contact	contact@wattandsea.com

*Designed and manufactured in France by :*

WATT&SEA SARL  
40 R Chef de Baie  
17000 La Rochelle  
FRANCE  
[www.wattandsea.com](http://www.wattandsea.com)

HYDROGENERATOR SERIAL NUMBER

CONVERTER SERIAL NUMBER

HYDRAULIC PUMP SERIAL NUMBER

## TABLE OF CONTENTS

<b>1. SAFETY NOTICE</b>	<b>4</b>
1.1. Mechanical hazard	4
1.2. Electrical hazard	4
1.3. Installation	4
1.4. Operation	4
<b>2. HYDROGENERATOR pack content</b>	<b>5</b>
<b>3. ADDITIONAL EQUIPMENT REQUIRED</b>	<b>6</b>
<b>4. MECHANICAL INSTALLATION</b>	<b>7</b>
4.1. Installing the propeller blades	7
4.2. Placing the device on the transom	8
4.3. Installing the bracket on the transom	9
4.4. Rigging the immersion/lifting system	10
4.5. Mounting the electronic converter	12
4.6. Mounting the hydraulic pump	13
<b>5. ELECTRICAL INSTALLATION.</b>	<b>14</b>
5.1. Three-phases wiring of the hydrogenerator	15
5.2. Using a solar panel	15
5.3. Connecting the converter to the batteries	15
5.4. Connecting the hydraulic pump to the batteries	17
5.5. Interpretation of the converter's Leds	17
5.6. Interpretation of the hydraulic pump Leds	18
<b>6. HYDRAULIC INSTALLATION</b>	<b>19</b>
6.1. Connecting the hydraulic circuit	20
6.2. Filling the oil tank and bleeding the circuit	20
6.3. Pump operation	21
<b>7. CHARACTERISTICS</b>	<b>22</b>
7.1. Technical characteristics	22
7.2. How it works	23
<b>8. MAINTENANCE</b>	<b>24</b>
<b>9. SPARE PARTS</b>	<b>24</b>
<b>10. Frequently asked questions</b>	<b>25</b>
10.1. Operation	25
10.2. Maintenance and repairs	26
<b>11. WARRANTY</b>	<b>27</b>
<b>12. REGISTER YOUR PRODUCT ONLINE</b>	<b>28</b>
<b>13. FORM REQUESTING AN AFTER-SALES SERVICE RETURN</b>	<b>29</b>

TABLE OF FIGURES

Figure 1 : components contents..... 5

Figure 2: Exploded view of the prop shaft..... 7

Figure 3 : Cradle dimensions..... 9

Figure 4 : View of the lowering and lifting line ..... 10

Figure 5 : Assembly of the lowering line using a low friction ring ..... 11

Figure 6: Dimensions of hydraulic pump ..... 13

Figure 7: Wiring schematic ..... 14

Figure 8: Phase converter wiring plan..... 14

Figure 9: battery connectors manual..... 17

Figure 10: Pump running ..... 18

Figure 11: Disconnecting the quick-release couplings (© LEGRIS) ..... 19

Figure 12: Hydraulic circuit blueprint..... 19

Figure 13: Oil filler cap ..... 20

Figure 14: Racing hydrogenerator dimensions..... 22

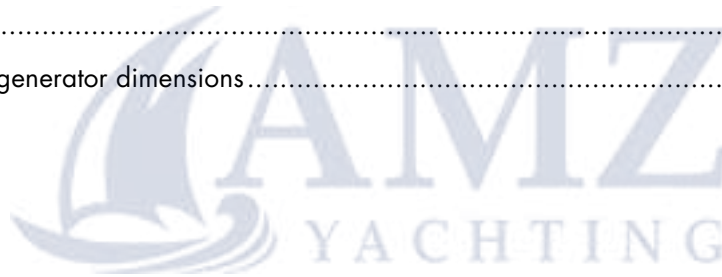

## 1. SAFETY NOTICE

While our primary concern in designing the hydrogenerator was your safety, certain precautions must nevertheless be taken when operating any mechanical or electrical equipment.

Please keep the following safety factors in mind when installing and operating the hydrogenerator, and be aware at all times of the electrical and mechanical hazards inherent in operating the propeller.

### 1.1. Mechanical hazard

The hydrogenerator's blades are made of a composite material and can rotate at a speed of over 100 kph (62mph). At this speed, the blades are practically invisible and can cause serious injuries.

**WARNING :**

- **WHEN INSTALLING THE HYDROGENERATOR, MAKE SURE THAT THE PROPELLER IS SAFELY POSITIONED OUT OF REACH.**
- **DO NOT ATTEMPT TO STOP THE PROPELLER WITH YOUR HAND WHILE THE GENERATOR IS RUNNING.**

### 1.2. Electrical hazard

Heat in wiring systems often results from undersized cables or faulty connections.

Batteries have a very high current carrying capacity. A short-circuit in their cables may result in an outbreak of fire. To prevent this hazard, you must install a 50 amp fuse between the converter and each battery.

If the fuse is defective, you must determine the reason before resetting or replacing it.

**WARNING :**

- **YOU MUST INSTALL AN EXTERNAL 50 AMP FUSE.**
- **ALWAYS PLACE THE HYDROGENERATOR IN THE LIFTED POSITION BEFORE STARTING WORK ON IT.**

### 1.3. Installation

Please observe the following precautions during installation :

- Remove the hydrogenerator from the water.
- Keep safety in mind at all times ! Have someone help you throughout the duration of the installation.
- Remember : the batteries should be connected last.

### 1.4. Operation

- Check the support structure, blades and electric circuits on a regular basis.
- Although the propeller blades are made of very strong materials, they may warp or break if they come into contact with a submerged object.

**WARNING :**

- **NEVER TOUCH THE PROPELLER WHEN IT IS SPINNING.**
- **NEVER USE THE HYDROGENERATOR TO STEP ONTO OR OFF THE BOAT AS THIS MAY WARP THE DRIVE SHAFT.**
- **WHEN RUNNING, THE CONVERTER CAN REACH VERY HIGH TEMPERATURES.**

## 2. HYDROGENERATOR PACK CONTENT

Check the package content against the list below:

- 1 RACING HYDROGENERATOR (PK-610-600-PV)
- 1 LIFTING BRACKET (KR-03)
- 1 HYDRAULIC PUMP (HPU-03)
- 1 CONVERTER (CV-03-PV) with its bag of connectors :
  - 1 hydrogenerator connector
  - 1 solar connector
  - 3 battery connectors
- 1 LOW FRICTION RING with rope
- 1 FASTENING KIT (F-03) with 2 stainless steel fork mountings and bolts
- 1 KIT OF BLADES
- 1 MANUAL



Figure 1 : components contents

### 3. ADDITIONAL EQUIPMENT REQUIRED

- Three-phase cable minimum  $3 \times 1.5\text{mm}^2$  for connecting the hydrogenerator to the converter
- Black and red  $10\text{mm}^2$  cable to be connected to the batteries
- Battery terminals for the  $10\text{mm}^2$  battery cable
- 50 Amp fuse or thermal circuit breaker (for example : Series 187 from Blue Sea Systems)
- Junction box or waterproof connectors for three-phase cables. WATT&SEA offers an optional connection kit with cable and waterproof power socket (Ref. WS-PL-C-002)
- Bolts & screws for the pump installation
- Gland  $\varnothing$  6mm
- Polyamide hydraulic tube  $6 \times 4\text{mm}$  (for example LEGRIS 1025P0601)
- High performance Mineral Oil extra fluid Viscosity Index 22 to 32 centistokes (type FUCHS Renolin Extra 22 S – minimum volume = 350 mL)
- A soldering iron for the hydrogenerator and solar connectors
- A heat gun to shrink the thermo-retractable boot
- Lifting/lowering line (6:1 hoist) with a 6 mm diameter covered line
- Install phonic insulation between the transom and the mounting bracket to minimize vibrations.

THE QUALITY OF THE POWER SOCKET IS PARAMOUNT: PREFERABLY CHOOSE A PLASTIC MODEL WITH GOLD PLATED CONTACTS QUALIFIED FOR 50 VCC - 12 AMP.

DO NOT USE METAL POWER SOCKETS WITH BRASS CONTACTS AS THESE CORRODE TOO QUICKLY.

## 4. MECHANICAL INSTALLATION

Your hydrogenerator is shipped partially disassembled. Please read the instruction manual carefully before starting installation.

### 4.1. Installing the propeller blades

- Remove the propeller cone (11), then the propeller blades support (10); pay attention to the spacer spring inside the shaft.
- Clip the blades into their respective slots in the hub. The mounting lug must be positioned behind the piston triangle (12).
- Remount the propeller blades support, with a moderate torque on the 3 screws CHC M5. Then, remount the cone with similar moderate torque on the CHC M5 screw. The blades must rotate freely inside their slots.

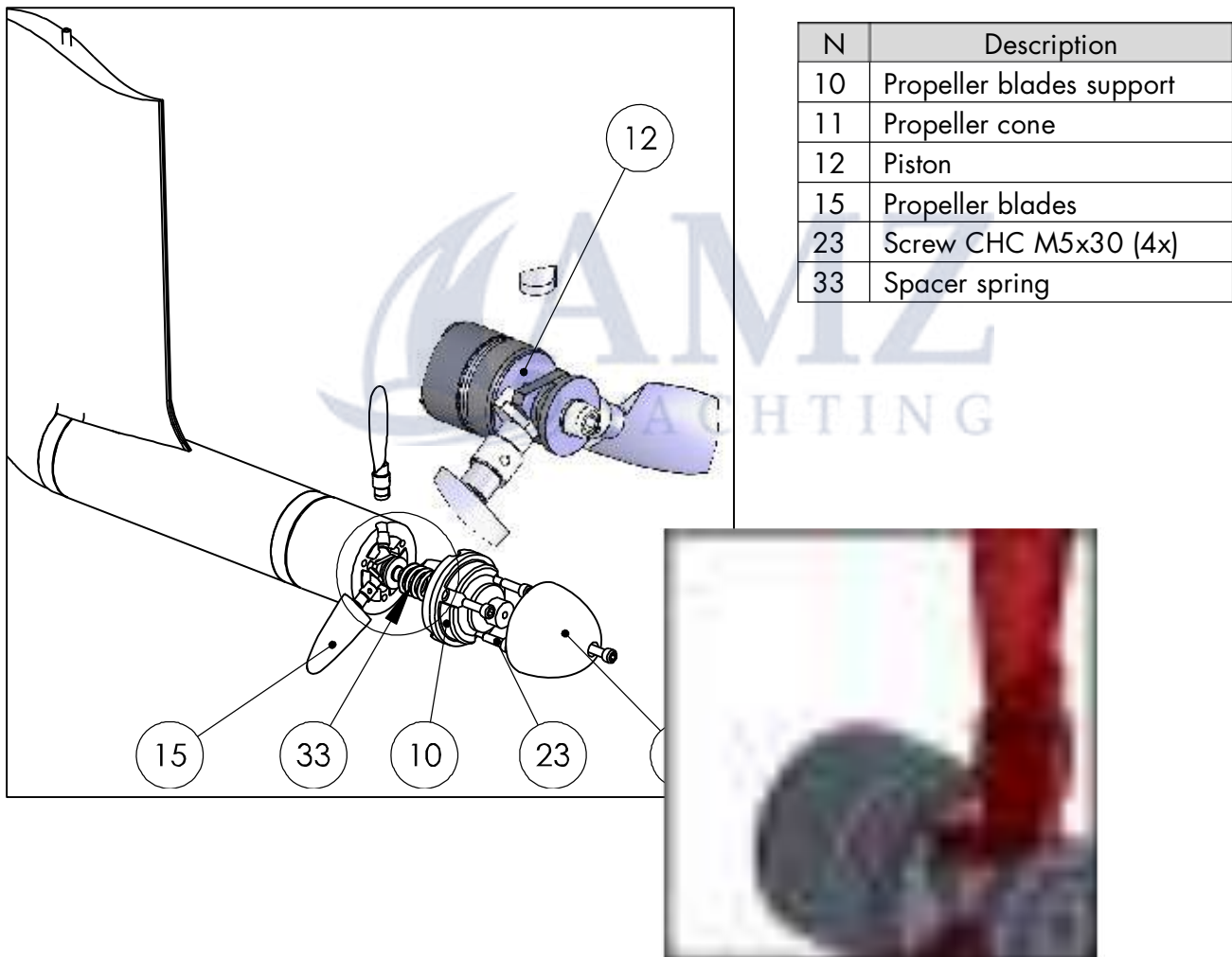

Figure 2: Exploded view of the prop shaft

## 4.2. Placing the device on the transom

Correctly positioning the hydrogenerator is crucial for optimizing its performance.

The following criteria must be respected during the installation :

- **Immersion depth:**

The recommended depth between the surface and the propeller axis is 30cm (12 inches).

The machine comes with a 610mm (24 in) aluminium profile and with a lifting bracket schedule to be fitted on a transom just upon the waterline.

The greater the depth, the farther the propeller will be from the wake of the hull, and the better the performance of the hydrogenerator. However, the most important the lever arm is, the greater the force on the mountings and during lifting will be.

For the boats of which the transom takes off while heeling, we recommend either a system to move the hydrogenerator from portside to starboard, or to install 2 units.

- **Flow quality:**

The quality of water flow is a key element for obtaining satisfactory power output.

**NOTE : Do not position the hydrogenerator directly in the wake of an appendage or too close to a saildrive.**

Wherever possible, position the hydrogenerator several inches to the side.

- **Linkage:**

Provide a mechanical locking system of the device in a vertical position so that all the degrees of freedom are blocked. In this way the device is less vulnerable in the event of flood water on the transom.



### 4.3. Installing the bracket on the transom

Depending on your boat's transom, its structure might need to be reinforced to take the stress on the mountings. Phonic insulation also reduces vibrations.

**WARNING : Due to the size of the lever arm, the maximum theoretical stress on the bracket's fork mountings is estimated at around 300 kg. Your mounting system should be adapted accordingly.**

The bracket must be adapted to the 8 mm diameter fork mountings that are securely mounted onto the transom. These fork mountings must be mounted in such a way as to compensate for any tilt of the transom. The diagram below will help you to adapt the mountings to your boat.

**N.B. : The leg must be vertical in the lowered position.**

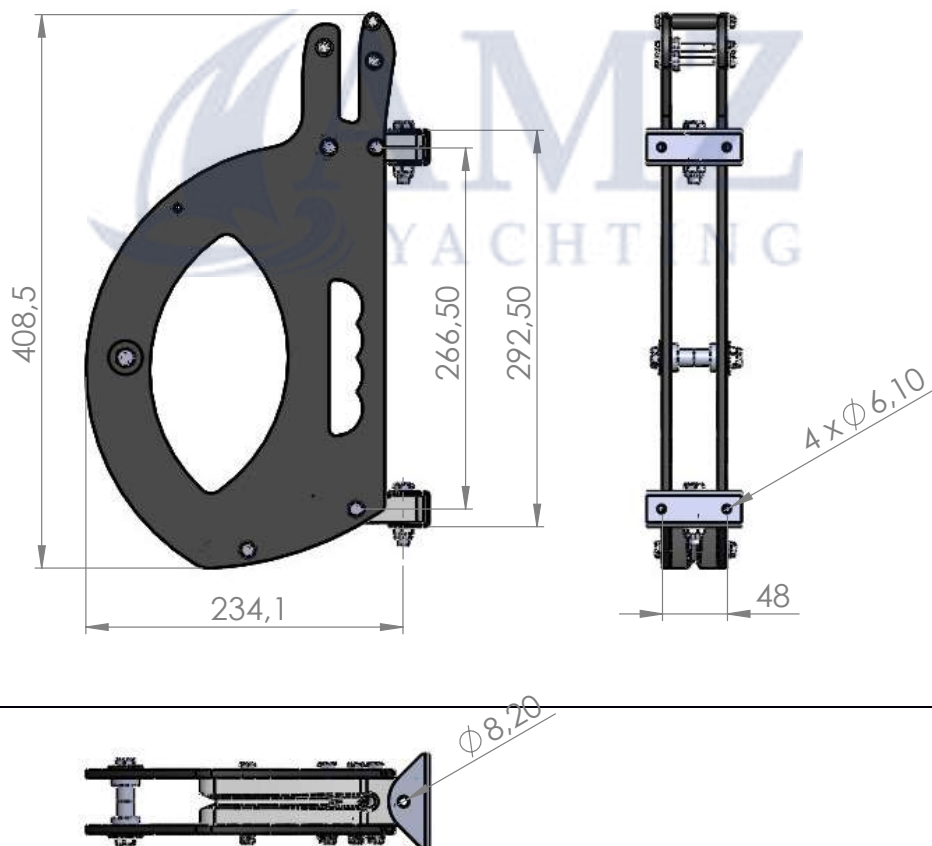

Figure 3 : Cradle dimensions

#### 4.4. Rigging the immersion/lifting system

The hydrogenerator is supplied with a lifting bracket that functions in a similar way to the systems used on the rudders. It facilitates access to the propeller when the device is lifted, for the removal of seaweed for example.

The lowering and lifting procedures are carried out using a hoist which is not included in the pack. The maximum traction during lifting is around 40 kg. It is therefore recommended to rig a 6:1 hoist with a 6 mm diameter sheathed line (hoist available in option at Watt&Sea).

To minimize the effort, it is advisable to install the low friction ring by tying a cow's hitch knot through the eyelet located under the bracket.

- Assembly of the ring on the leg :

Pass the rope of the low friction ring through the hole of the leg located under the bracket and attach it with a lark's head knot (see picture below)

- Assembly of the lowering rope :

Pass the rope successively :

- in the cam-cleat of the bracket
- in the two gudgeons of the bracket
- through the low friction ring
- in the hole of the lower gudgeon
- Finish the assembly by an eight-knot (see picture below)

The cleat integrated into the bracket is used to lock the lowering and lifting line. For permanent blocking, you can use the locking pin.

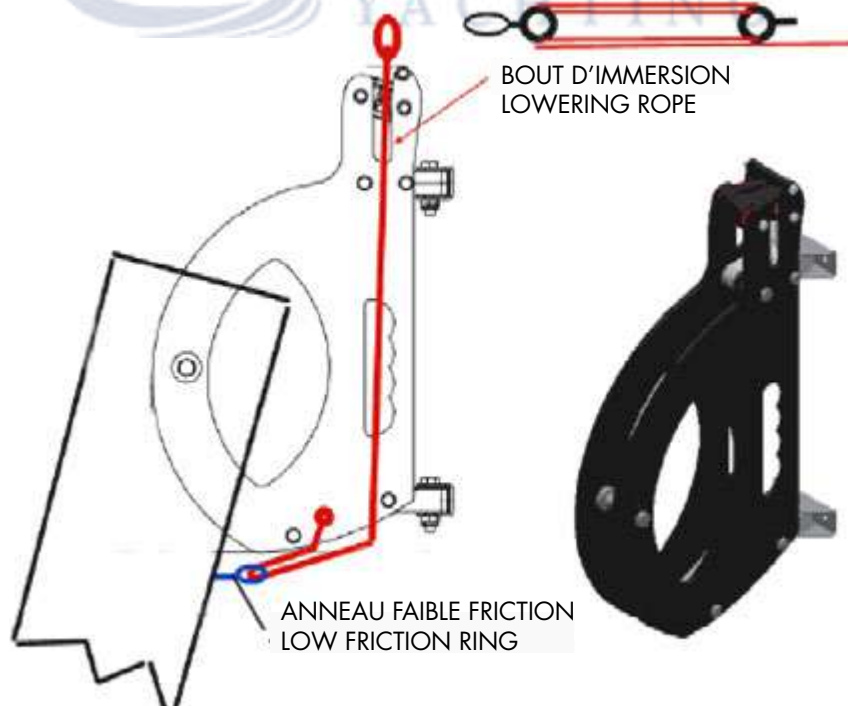

Figure 4 : View of the lowering and lifting line



Figure 5 : Assembly of the lowering line using a low friction ring

**N.B. : When the hydrogenerator is submerged, the leg should sit flush in the groove of the gudgeon provided for this purpose. If this is not the case, the lateral support will be less efficient, and this may result in mechanical damage.**

It is also advisable to hold the lifting end in place using an elastic cord to prevent it from leaving the groove.



## 4.5. Mounting the electronic converter

The electronic converter is a box which is resistant to splashes and passive ventilation, guaranteeing long-term protection even in humid environments.

The converter must nevertheless be installed inside the boat, preferably in the mechanical room in close proximity to the batteries.

**WARNING : WHEN RUNNING, THE CONVERTER CAN REACH VERY HIGH TEMPERATURES. AS SUCH, ASSEMBLY SHOULD BE CARRIED OUT IN A VENTILATED SPACE.**

**NOTE : To ensure proper ventilation, the converter must be mounted on a vertical bulkhead, with the ventilation grids in a vertical position.**



As it is so light, the converter can be securely attached using the Velcro provided.

- degrease the surface on which the converter will be installed
- remove the protective tabs of the strips of Velcro provided on the converter
- apply the quick-drying glue if the surface is very uneven (against plywood, fibreglass ...)
- firmly attach the converter to the surface

## 4.6. Mounting the hydraulic pump

The hydraulic pump is delivered in a waterproof casing that contains the electrical panel, the pump and its oil tank. Two switches located on the side of the pump allow an easy manual control of the blade's position.

The casing must be placed vertically, if possible near the converter and in an accessible location.

**Note : The casing of the pump must be placed vertically.**

Once the location is chosen, follow the procedure below:

- Pre-drill 4 holes using the template provided (212x122mm)
- Open the cover by removing the 4 screws
- Screw the waterproof casing into place, then re-place lid

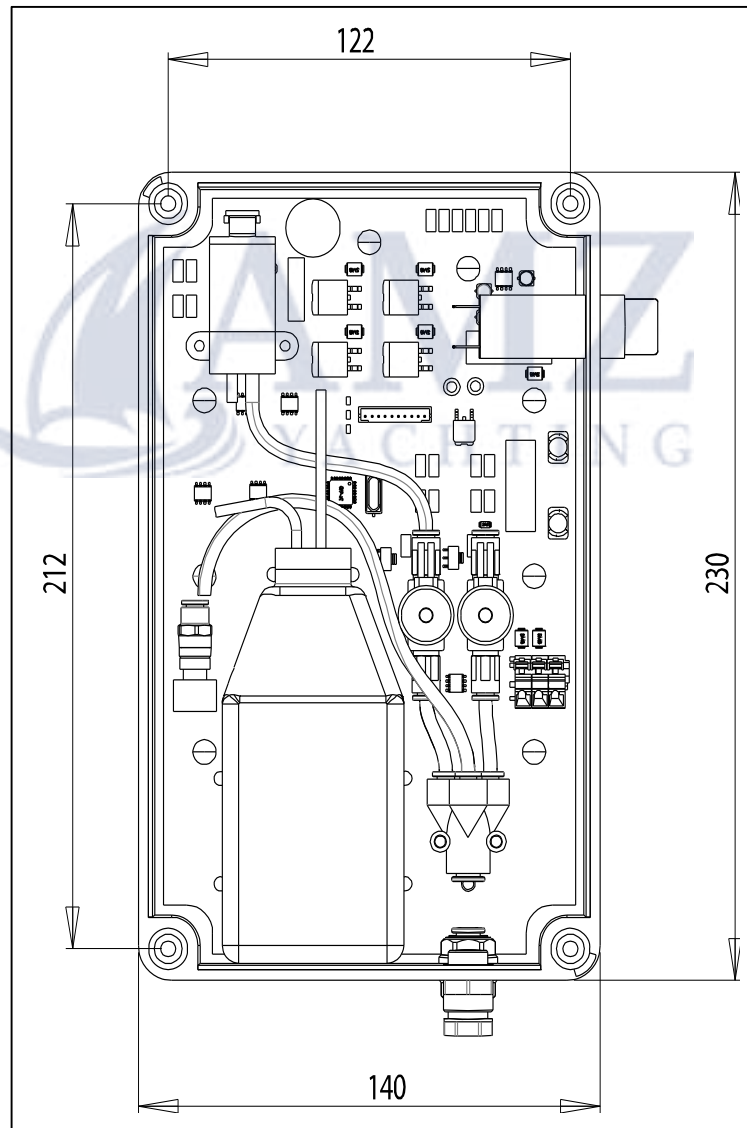

Figure 6: Dimensions of hydraulic pump

## 5. ELECTRICAL INSTALLATION.

Recommendations regarding electric connections:

- Please consult local/national safety rules before installation.
- All electric cables must be carefully insulated. For maximum protection, cover the cables with electrical cable sheaths.

**WARNING: CONNECTIONS MUST BE INSPECTED REGULARLY TO DETECT ANY SIGNS OF CORROSION AND CLEANED WHEN NECESSARY.**

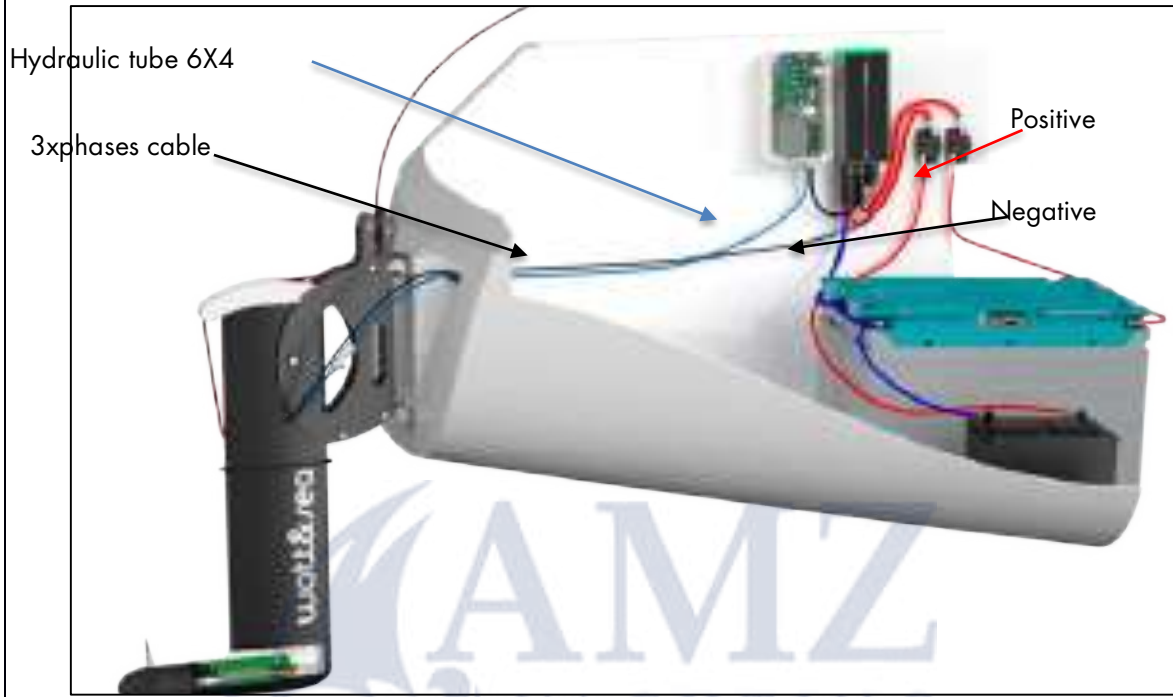

Figure 7: Wiring schematic

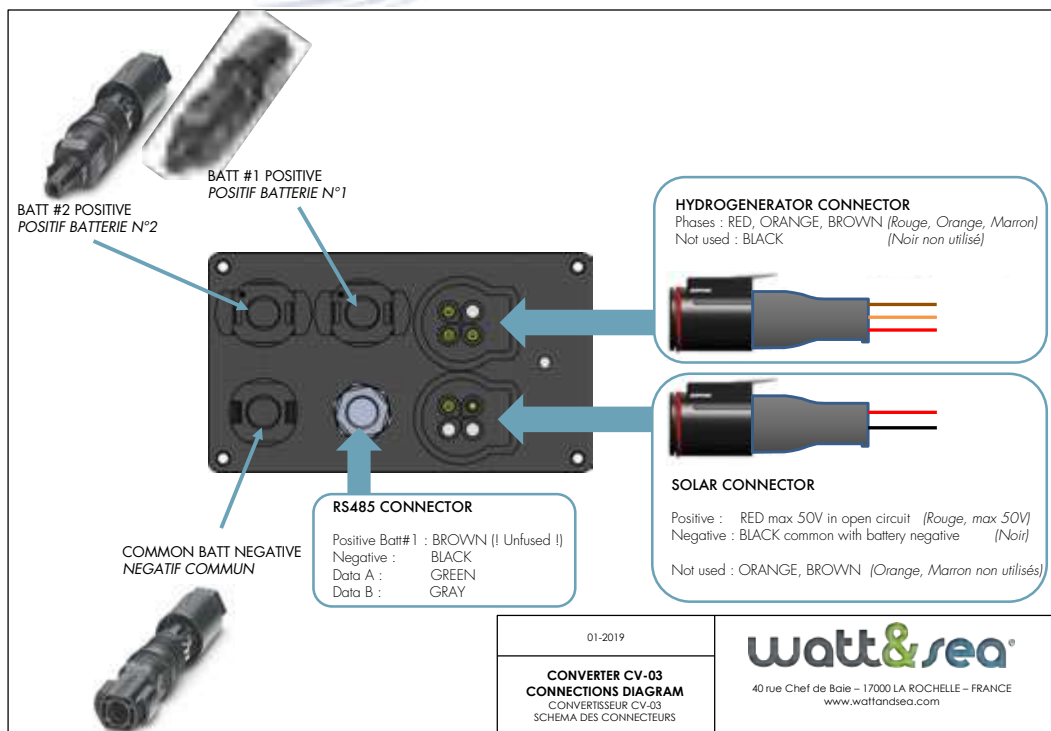

Figure 8: Phase converter wiring plan.



## 5.1. Three-phases wiring of the hydrogenerator

**WARNING : ALWAYS PLACE THE HYDROGENERATOR IN THE LIFTED POSITION BEFORE STARTING WORK ON IT.**

The hydrogen generator has a short cable at the outlet, long enough to fit into the boat. This cable is composed of three phases. If it is necessary to extend it, at least 3x1.5mm<sup>2</sup> should be used.

Then connect the 3 phases to one of the supplied sockets without using the EARTH conductor (green/yellow). There is no order to connect to the other conductors (brown, grey, black). For example, you can use WAGO 222 connectors.



Connect this plug to the input labeled "HYDRO".

**NOTE : The phase sequence is irrelevant. Therefore, there is no need to take into account the color or numbering of the cables.**

## 5.2. Using a solar panel

The converter has a second input for a solar panel. The maximum solar panel voltage must not exceed 50 VDC and current 12 Amperes. The minimum voltage at which the converter can start charging is 7.5 VDC.

When the hydrogen generator and solar panel produce at the same time, priority is given to the hydrogen generator. As soon as it does not produce any more (stopped, anchorage...) the converter automatically takes into account the load of the solar panel.

Connect the solar panel to the 2nd socket provided, respecting the following polarity:

**SOLAR NEGATIVE : green/yellow**

**SOLAR POSITIVE (50 V max) : grey**

Connect this plug to the input labeled "SOLAR".

**CAUTION: OBSERVE THE POLARITY OF THE SOLAR PANEL**

## 5.3 The converter to the batteries

The converter must be placed as close as possible to the batteries in order to minimize losses due to cable length. The maximum recommended distance is 2 metres.

The batteries are connected to the converter via a solar connector.

The converter has an internal 2 output isolator that makes it possible to charge two battery units separately. The 2 battery banks must be at the same voltage.

The hydraulic pump is powered from output #2. If only one output from converter is used, you must use the #2 to feed the pump. (see Fig. 8)

**WARNING : RISK OF OVERLOADING AND FIRE. THE TWO BATTERY BANKS MUST BE THE SAME TYPE AND HAVE THE SAME VOLTAGE.**

**WARNING : EACH BATTERY BANK MUST BE PROTECTED WITH A 50 AMP FUSE.**

We recommend connecting the hydrogenerator's converter directly to the service battery bank. The converter will monitor the batteries independently of the other on-board units, and will charge them when required.

**N.B. : Proper operation on one external battery isolator is not guaranteed and may require additional adjustment. Please contact your distributor.**

**WARNING : NEVER REVERSE THE POLARITY OF THE CONVERTER. THIS WILL LEAD TO THE DESTRUCTION OF THE DEVICE.**

## English

### SUNCLIX photovoltaic I/O connector for installation in photovoltaic systems for 6 ... 16 mm<sup>2</sup> solar cables, type PV1-F

#### 1 Safety notes



**WARNING:**The SUNCLIX plug-in connectors may be connected only by trained electricians.



**WARNING:**Never plug in or disconnect the SUNCLIX plug-in connectors under load.



**NOTE:** Use these plug-in connectors only in combination with a 6 ... 16 mm<sup>2</sup> solar cable, type PV1-F. A safe, electrical connection is only possible with this cable. When laying out the cable, observe the bending radiuses that the manufacturer specifies.



**NOTE:** Connect this plug-in connector only with other SUNCLIX photovoltaic plug-in connector. When making the connections, be sure to observe the specifications on nominal voltage and nominal current. The smallest common value is permissible.



**NOTE:** Protect the plug-in connectors from humidity and dirt.

- Do not immerse the plug-in connector in water.
- Never lay out the plug directly on the roofing.
- Attach a protective cap (e.g. PV-C PROTECTION CAP, order number 1785430) to plug-in connectors that are not plugged in.

#### 2 Connecting connectors

You need a slot screwdriver with a 3-mm wide blade (e.g. SZF 1-0.6X3.5; item no. 1204517).

##### 2.1 Connecting the cable (Fig. ①)

- Strip the cable by 18 mm with a suitable tool. Make sure that no individual wires are cut off.
- 1 Carefully insert the stripped wire all the way in. The litz wire ends have to be visible in the spring.
  - 2 Close the spring. Make sure that the spring is snapped in.
  - 3 Push the insert into the sleeve.
  - 4 Tighten the cable gland to 3 Nm.

##### 2.2 Assemble the connector

- Bring the plug and the socket together. The connection snaps close thereby.
- Pull on the coupling to check the proper connection.

##### 3 Separating the connector (Fig. ②)

- 1 Insert the screwdriver as shown in Fig. ②.
- 2 Leave screwdriver inserted and disconnect the plug and the socket from each other.

##### 3.1 Loosen the cable (Fig. ③)

- 1 Screw open the cable gland.
- 2 Insert the screwdriver at the position shown in Fig. ③.
- 3 Pry the connection open and pull the sleeve and the insert apart.
- 4 Open the spring with the screwdriver.
- 5 Remove the cable.

#### 4 Technical data

Ambient temperature: -40 °C ... +90 °C  
 Nominal voltage: max. 1500 V DC  
 Nominal current: 40 A (6 mm<sup>2</sup>), 50 A (10 mm<sup>2</sup>), 65 A (16 mm<sup>2</sup>)  
 Cable diameter: 5,5 ... 10 [mm]



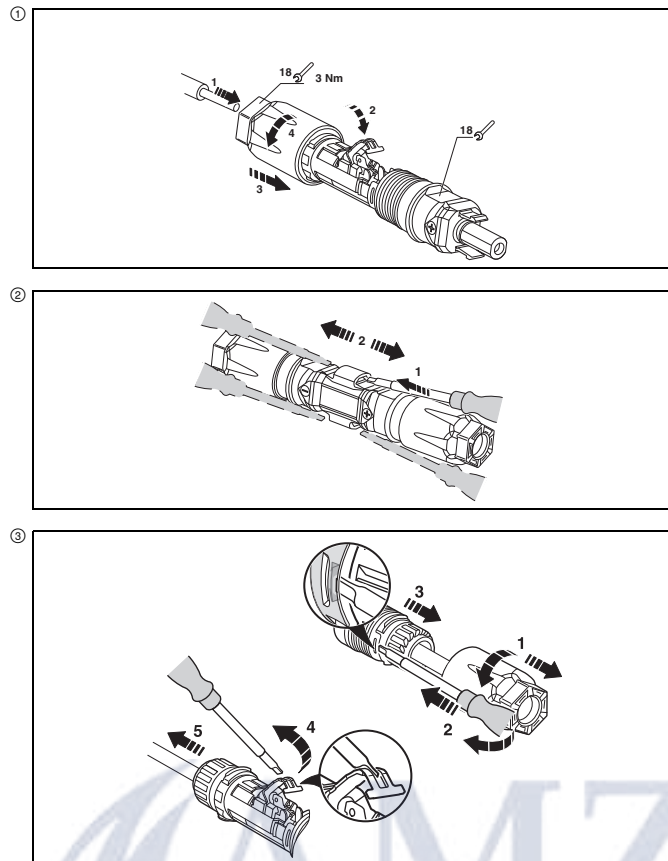

Figure 9: battery connectors manual

### 5.3. Connecting the hydraulic pump to the batteries

The hydraulic pump must be placed in an accessible position, with good access to all the switches and the oil gauge.

The pump is powered directly through the provided connector, from the output#2. If only one of the two available converter outputs is used, the #2 must be used.

Check the correct functioning of the device by putting it in "manual" mode, and activate "pump". The pump must turn under the manual impulse.

**WARNING : DO NOT RUN THE PUMP DRY IN A PROLONGED WAY AS LONG AS THE PUMP IS NOT FILL IN OF OIL.**

### 5.4. Interpretation of the converter's Leds

- When the converter is not charging, the battery voltage is indicated by a pulse of color which changes from green (12.8 V) to red (11.5 V).
- When the converter is charging, the output power is indicated by a constant color which changes from violet to blue (120W), to light blue (240W) and finally to white (480W).

- Green or red colored flashes may overlay the display of the constant color to indicate statuses or anomalies :

SITUATION	VISUAL	COMMENTS
Absorption voltage reached	1 brief green flash every 5 seconds	The battery is full (absorption voltage = 14.3 V / 28.6 V)
Floating voltage maintained	1 long green flash every 5 seconds	The battery is kept at 100% (floating voltage = 13.8 V / 27.6 V)
Overheating	1 red flash every 5 seconds	The maximum box temperature has been reached
Generator anomaly	2 red flashes every 5 seconds	The hydrogenerator's connection is defective
Overvoltage at input	3 red flashes every 5 seconds	The solar panel or the hydrogenerator are applying a voltage that is too high
Another anomaly	4 red flashes every 5 seconds	Contact your distributor

### 5.5. Interpretation of the hydraulic pump Leds

The hydraulic pump is equipped with several Led's to indicate the system status :

- 1 green Led as a power indicator (ON)
- 1 red Led as an error communication indicator (ERR)
- 1 green Led (RCV) to indicate data reception 3 times per second
- 1 8-Leds Bargraph on the right to indicate the pressure inside the system, measured in Bars.

At high speed there should be 4-8 Bars. At low speed, there should be between 0 and 4 Bars.

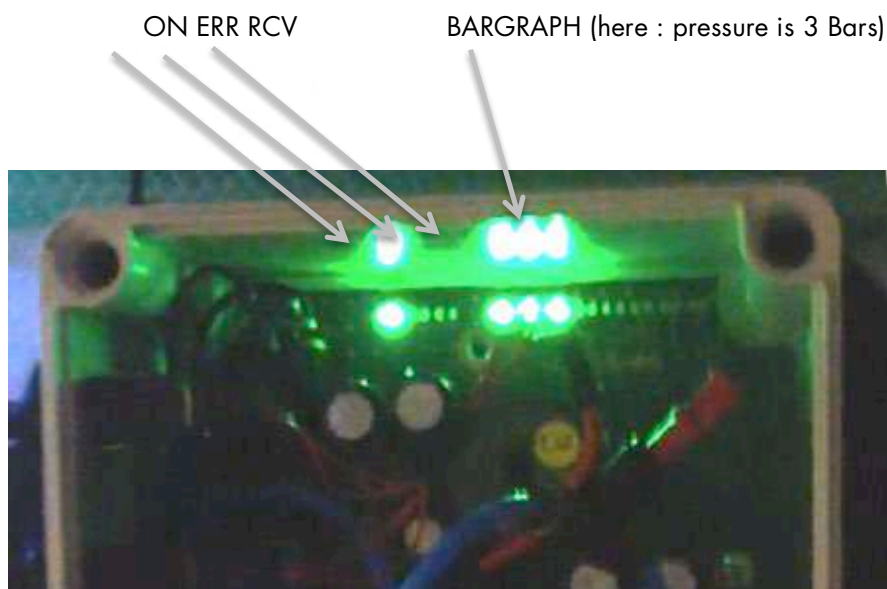

Figure 10: Pump running

## 6. HYDRAULIC INSTALLATION

The hydraulic pump controls the pitch of the hydrogenerator blades.

The pump is designed to be matched to a polyamide tubing, exterior diameter of 6mm (~1/4") (for example LEGRIS 1025 P06 01).

In order to connect multiple hydrogenerators to the same pump, you must use a T-junction, diameter 6mm (for example LEGRIS 3104 06 00)

The quick-release couplings can be used without tools. First, depressurize the circuit, then push the ring in and slide the tube out. The tube must slide out easily.

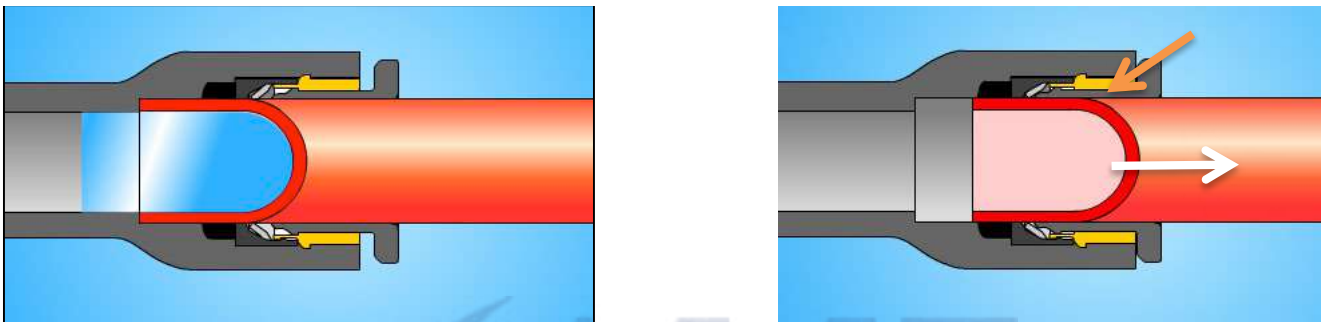

Figure 11: Disconnecting the quick-release couplings (© LEGRIS)

The pump housing contains a hydraulic micro-pump, a check-valve, a solenoid and a digital pressure gauge

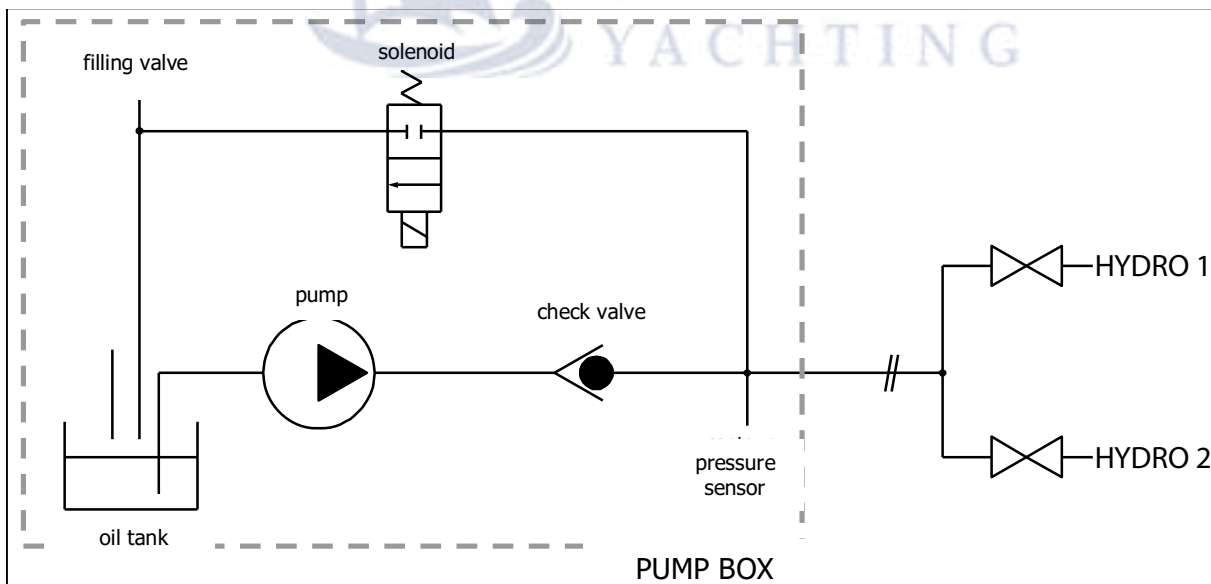

Figure 12: Hydraulic circuit blueprint

## 6.1. Connecting the hydraulic circuit

Thread the hydraulic tubing from the transom to the pump.

Connect the pump to the circuit with the quick-release couplings located on the lower section of the housing.

**Note : At this point, do not connect the hydrogenerators**

## 6.2. Filling the oil tank and bleeding the circuit

Place a bucket to collect the oil that will be drained during the bleeding process.

Fill the oil tank with mineral oil (low viscosity type FUCHS Renolin Extra 22 S). This tank has a capacity maximum of 300 mL.

To fill the tank, remove the filler cap and use a large caliber syringe.

When the tank is full, bleed the circuit using switch in manual and "pump" mode (maintain the "pump" switch under pressure).

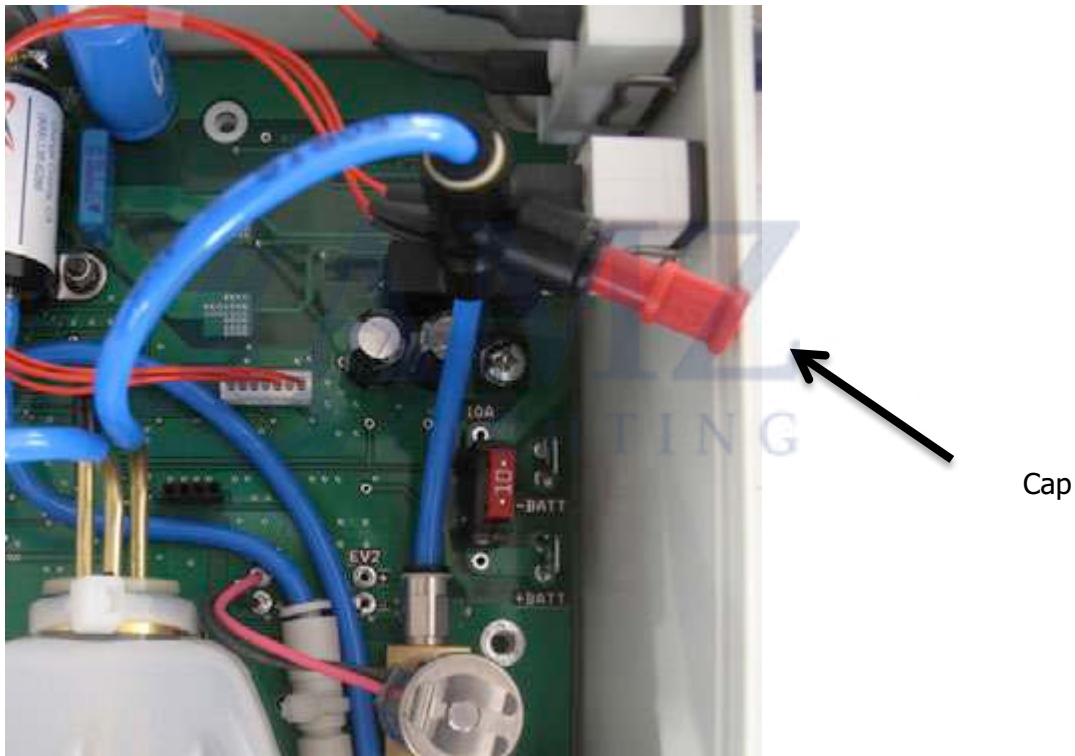

Figure 13: Oil filler cap

When you have finished bleeding the circuit, you can connect the hydrogenerators and top up the oil level.

**Fill the oil tank to  $\frac{3}{4}$  capacity, in order to leave a margin for the good functioning of the device during operation.**

Verify in manual mode that the blades rotate and adjust correctly when following the preset commands.

If the blades are not moving, the hub screws might be too tightened or blades could be not correctly mounted.

### 6.3. Pump operation

Two switches are available on the side of the pump.

In MANUAL mode : One pressure on PUMP button gives the order to send an increment of hydraulic pressure. This allow to rotate the blades step by step to feather position.

One pressure on RELEASE button has the opposite effect with releasing the oil back to the tank;

In AUTO mode : One pression on PUMP button sends the maximum pressure in the system to fully feather the blades. This is useful for immersion procedure to set the hydrogenerator in position where it has the least drag.

As soon as a rotation of the propeller is detected, the pump algorithm will start and regulate the pitch.

If no rotation is detected after 2 minutes, the pressure is full released.

When operating, the AUTO mode regulates the blades pitch to stay in an acceptable range of RPM and power. This has for effect to reduce the drag to the minimum possible.



## 7. CHARACTERISTICS

### 7.1. Technical characteristics

- Hydrogenerator :

Nominal power : 600W

Voltage : 3-phase 40V

Current : 9A

Weight : 7,6 kg / 8,6 kg

Dimensions : 770 x 453 x 70 mm

- Converter :

Nominal power : 600W

Regulated voltage ABS : 14,3V or 28,6V Floating

voltage : 13,8V or 27,6V

Weight : 1,5 kg

Dimensions : 210 x 105 x 60 mm

- Hydraulic Pump :

Power supply : 10V to 36V

Tank capacity : 300mL

Max Pressure : 7 bars

Weight : 1 kg

Dimensions : 250 x 165 x 100 mm

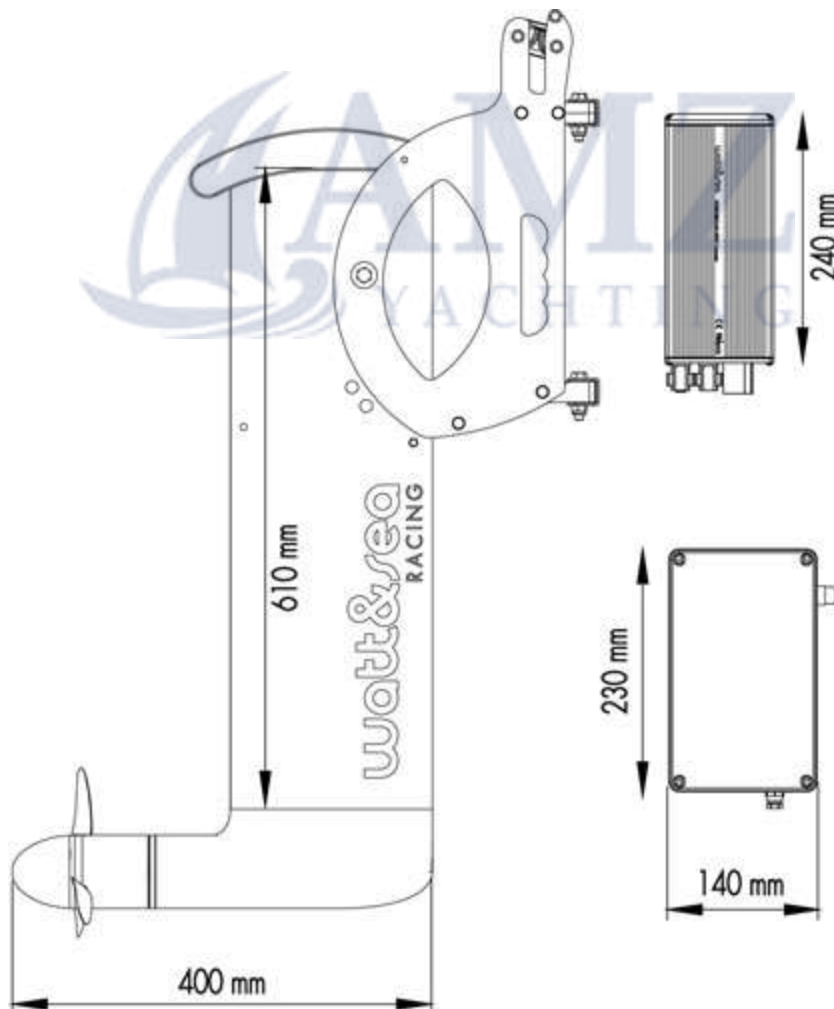

Figure 14: Racing hydrogenerator dimensions

## 7.2. How it works

- The hydrogenerator :

It includes a permanent magnet alternator producing very low 3-phase current (0-40V). This technology allows high efficiencies, but also generates high voltage during over-speed.

- Protection against overvoltage:

To avoid going over 40V volt ages, the hydrogenerator is made of an electronic which short-breaks for a while the alternator in case of over-speed. This circuit is embedded in the generator and protects the entire circuit downstream.

When the device works over-speed, it produces a specific and audible rumble.

This can occur for several reasons:

1 - A cable has been disconnected or the fuse blew and the converter is not anymore linked to the batteries. The device runs 'freewheel' and is not slowed down anymore by the electromagnetic force. The converter may be switch off.

2 - The three-phase cable is completely disconnected. In this case, the LEDs indicate a pulsating color in the range red, orange, green, indicating that the battery is connected, but there is no input power arrival.

3 - One of the three-wire cables is disconnected. In that case, the converter keeps on loading but in a lower way. The status of the led must show a fixed colour in the purple, blue, white range, on which will overlay 2 red flashes every 5 seconds.

4 - Batteries are full or the battery park capacity is too weak. The converter has fully loaded the batteries, or they cannot absorb enough energy to slow the propeller. The converter should indicate this status with a green flash every 5 seconds.

5 - The boat sails over the propeller speed range and the converter is stuck to its maximum capacity.

- Regulation of the wedging:

On the racing model, pales modify their incidence according to the speed of the boat and the load of batteries. In this way, the protection anti-surge brings in in service only in case of transients or safety and the drag is optimal whatever is the speed.

The regulation of pales is made by impulse when the speed of the turbine goes out of a predefined range. This regulation is made in automatic mode when the switch " manu / auto" is positioned on "auto". It is however possible to force this regulation by positioning the switch on the manual mode and by settling the slope of pales with the switch " release / pump ".

- The converter :

The converter is transforming the alternative voltage of the alternator in a continuous voltage compliant with batteries. This voltage is reached only when batteries are full. In normal functioning, the in board voltage is lower than 14,3V or 28,6V (absorption phase). When conditions allow loading batteries at 100%, the converter regulates a lower voltage (13,8V/27,6V) in order to maintain batteries without damaging them (floating phase).

## 8. MAINTENANCE

The hydrogenerator has been designed for offshore races and benefits from the latest technology for its reliability. Metallic parts are made either in specially treated aluminium or in stainless steel A4.

An optimum sealing is obtained with a hi-tech ceramic-aluminium gasket used in industry. These gaskets have a lifetime of several thousands of hours and will painlessly support a circumnavigation.

The housing is filled with lubricating oil that is slightly pressured to prevent any water seepage.

The device does not need any particular maintenance other than cleaning external parts.

- Regularly clean the body of the device
- Check regularly that the device mountings and the propeller are tight enough
- Check that all the electrical connections are tight and clean (not corroded)
- Do not operate the hydrogenerator with damaged or unbalanced propeller blades. This might cause a premature wear, or a break down. Replace the propeller as soon as possible.

WATT&SEA recommends a revision at least every two years or every 10,000 miles. WATT&SEA proposes revision packages to suit all your needs. Information available on [www.wattandsea.com](http://www.wattandsea.com) or at your dealer.

<b>REGULARLY CHECK THE CONNECTIONS</b>
----------------------------------------

## 9. SPARE PARTS

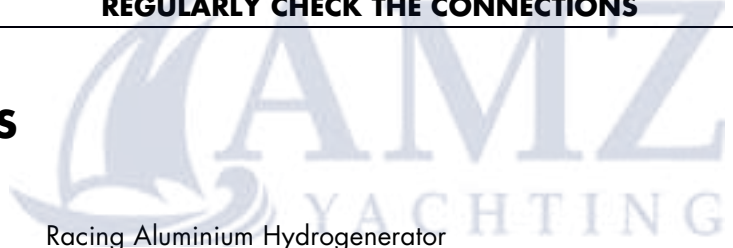

PK-610-600-PV/CAR	Racing Aluminium Hydrogenerator
CV-03-PV	12-24 Vcc auto-detected convertor for hydraulic pump
P-R-002	Blades kit
KR-02	Lifting bracket
HPU-03	Hydraulic pump



## 10. FREQUENTLY ASKED QUESTIONS

### 10.1. Operation

- What power can it produce?

The power generated increases at the cube of the speed ( $V^3$ ). At 7 knots, the output power is about 120W (or about 10Amp on a 12V battery). At 11 knots, the system produces 4 times more power, i.e. 480W (about 40A on a 12V battery). These figures are instantaneous measurements and averages might be different according to the condition at sea.

- What happens when the batteries are charged ?

The electronic regulator automatically charges the batteries to their proper level. When full, the propeller freewheels. which has the effect of reducing the drag of the system. The blades are then automatically feathered .

- Is the hydrogenerator producing a rumbling sound ?

This means that the batteries are full. The hydrogenerator starts to freewheel and produces a thudding, almost rumbling sound.

- Is it possible to use the hydrogenerator with the engine ?

The system is not designed to replace the engine's alternator. It can nevertheless be used while operating your engine. This presents no mechanical risk. However, electrical output will be significantly disrupted depending on the location of the generator and the water turbulence caused by the engine.

- Is it possible to use the hydrogenerator in reverse ?

The hydrogenerator must be lifted when reversing the boat in order to avoid cantilever damaging the leg and bracket mountings.

- The hydrogenerator does not charge as much as is shown in the charts, why is this ?

The two most common causes of under-production are :

- An electrical connection problem : socket poorly connected/assembled, socket damaged/corroded, cable cut or pinched.
- The hydrogenerator is positioned along the axis of an appendage (rudder, keel, etc.) disrupting the flow of water and affecting production.
- We suggest that you consult the help centre on our website to check that your device is operating correctly : <http://www.wattandsea.com/help-center>

- Do the converter's LEDS consume energy ?

The converter has a residual consumption as one LED is always lit. It cuts out in the event of low voltage (11.9V) in order to save the battery. Generally speaking, you can consider that the standby consumption is less than the self-discharge of the batteries.

- Ion lithium batteries ?

The converter is designed to charge lithium batteries as its voltage is regulated and cannot exceed the maximum value of 14.3 V (or 28.6 V).

It can be programmed with specific voltages, please contact us.

## 10.2. Maintenance and repairs

- How reliable is the system ?

The reliability of the hydrogenerator has been demonstrated in many ocean and round the world races. It benefits from advanced technological expertise as regards resistance.

- What maintenance will the system require ?

Except for external cleaning, the hydrogenerator requires no specific maintenance.

However, think about :

- regularly disassembling the propeller to remove any dirt from the hub
- checking the condition of the leg's output cable (no of cuts or pinching)
- checking the condition of external sockets (no corrosion)

WATT&SEA recommends servicing every two years or every 10,000 miles.



## 11. WARRANTY

**Coverage and warranty period:** Our products are designed for very specific conditions of use. It is the responsibility of our customers to ensure the appropriate use of our products. Our systems are covered by a two-year warranty against any manufacturing defect. The warranty period starts on the date of purchase of our products by the distributor.

The warranty is limited to the standard replacement of a defective part or, if necessary, the entire system, upon receipt of the part in question. Under civil law, it is the responsibility of the purchaser to fulfil the burden of proof regarding the previous nature of the claimed latent defect.

Any returned systems or parts must be accompanied by the warranty returns form (see below), duly completed as follows: name and address of the customer, date of purchase, type of boat, defective parts, description of the structural or design defect, and description of the conditions under which the system was used.

Returned systems or parts shall only be accepted with the prior written consent of WATT&SEA, and must be returned by prepaid shipment. Should the replacement of the WATT&SEA product prove to be due to a defect covered by the warranty, these shipment costs shall be refunded.

Under no circumstances shall returned systems or parts be refunded; they shall only be replaced.

### **Situations not covered by the warranty:**

This warranty shall not apply if the system in question:

- has suffered an accident, or undergone unauthorized alterations or repairs;
- has not been installed by a professional installer in strict compliance with the procedure specified by WATT&SEA in the installation and user manual supplied with the generator;
- has been:
  - o installed or serviced in an inappropriate manner, or used under too high a charge;
  - o subjected to abuse or neglect;
  - o used when reversing.

The warranty shall not take into account any failures due to simple wear and tear or normal ageing of the structures and materials, any scratches, or any cracks or starring that may appear following an impact.

Under no circumstances shall WATT&SEA be liable for any special, incidental or consequential damages.

**Should you encounter a problem with your WATT&SEA hydrogenerator**, please contact your distributor/installer.

## 12. REGISTER YOUR PRODUCT ONLINE

For traceability under the warranty, please register the product on our website: [www.wattandsea.com](http://www.wattandsea.com). You will benefit from:

\* Confirmation of ownership and safety notices : by registering online we can use your saved details to track your product and contact you quickly if necessary.

\* Product information and news: choose to be among the first to hear about our latest products, product developments and receive helpful advice !



### 13. FORM REQUESTING AN AFTER-SALES SERVICE RETURN

Owner	
Name:	Phone no.:
Address:	E-mail:
	Country:
Date of purchase of the hydrogenerator: Serial no. (see installation manual) - of the hydrogenerator:  - of the converter:	Type of boat:  Type of assembly on the transom (if custom-made, please specify):
Conditions of use (frequency/specific conditions having revealed the defect):	
Defect noticed:	
Date:	
Signature:	
Retailer/Installer	
Name:	Phone no.:

Address:	E-mail:
	Country:
Date of purchase of the hydrogenerator:	Has the defect been confirmed?
Has the installation been carried out in compliance with the instruction manual?	Installer contact details:
Defective subassemblies to be replaced:	
	
Date:	Signature:
After Sales returns authorization no.:	